

Diagram References

1 Appearance

- ① Microphone ② Low Illumination IR Supplement Light ③ Built-in Camera
- ④ Loudspeaker ⑤ Call Button ⑥ Nametag ⑦ TAMPER
- ⑧ Network Interface ⑨ Module-Connecting Interface ⑩ Set Screw

Note: The module-connecting interface is used to connect other function module, such as nametag module, keypad module, card reader module, etc. All these modules are known as sub module.

2 Terminal

- ① NC1: Door Lock Relay Output (NC)
- ② NO1: Door Lock Relay Output (NO)
- ③ COM: Common Interface
- ④ NC2: Door Lock Relay Output (NC)
- ⑤ NO2: Door Lock Relay Output (NO)
- ⑥ GND: Grounding
- ⑦ 12 VDC: Power Input
- ⑧ GND: Grounding
- ⑨ PoE Network Interface (Supports IEEE 802.af/at-Compliant Devices)
- ⑩ AIN2: For the access of Door Contact 2
- ⑪ AIN1: For the access of Door Contact 1
- ⑫ AIN3: For the access of Exit Button 1
- ⑬ AIN4: For the access of Exit Button 2
- ⑭ 485-: Module-connecting Interface
- ⑮ 485+: Module-connecting Interface
- ⑯ 12V OUT: Module-connecting Interface
- ⑰ GND: Module-connecting Interface

Note: When you connect to 12VDC power input and PoE switch at the same time, the priority of 12 VDC is higher than PoE Switch. When the device is powered off, you should to disconnect the network cable from PoE Switch before disconnecting the power cable.

3 Installation

Note: Video intercom module door station support one-module installation, two-module installation, three-module installation and more-than-three-module installation. Here takes three-module installation as an example.

Before You Start

- Tools that you need to prepare for installation: Drill(6), cross screw driver (PH1*150 mm), and gradienter.
- Make sure all the related equipment is power-off during the installation.
- Make sure you have configured the sub module address before installation. Valid sub module address range is 1 to 8. The No. should be unique for sub modules that connected to the same main unit. The sub module address and corresponding switch status is shown as the figure.

Sub Module	Address	DIP 1	DIP 2	DIP 3	DIP 4	DIP 5	DIP 6	DIP 7	DIP 8
Module 1	1	ON	OFF	OFF	OFF	OFF	OFF	OFF	OFF
Module 2	2	OFF	ON	OFF	OFF	OFF	OFF	OFF	OFF
Module 3	3	ON	ON	OFF	OFF	OFF	OFF	OFF	OFF
Module 4	4	OFF	OFF	ON	OFF	OFF	OFF	OFF	OFF
Module 5	5	ON	OFF	ON	OFF	OFF	OFF	OFF	OFF
Module 6	6	OFF	ON	ON	OFF	OFF	OFF	OFF	OFF
Module 7	7	ON	ON	ON	OFF	OFF	OFF	OFF	OFF
Module 8	8	OFF	OFF	OFF	ON	OFF	OFF	OFF	OFF

★ Three-Module Flush Mounting

1. Cave the installation hole, and pull the cable out.
Note: The suggested dimension of the installation hole is 321.8(W) × 108(H) × 45.5(D) mm. The suggested length of the cables left outside is 270 mm.
2. Select a cable entry and remove the plastic sheet. Route the cables through the gang box hole. Insert the gang box into the installation hole. Mark the gang box screw holes' position with a marker, and take out the gang box.
3. Drill 4 holes according to the marks on the wall, and insert the expansion sleeves into the screw holes. Fix the gang box with 4 expansion bolts. Fill the gap between the gang box and wall with concrete or Silicone sealant. Remove the mounting ears with tool after concrete is dry.
4. Connect cables and insert the modules.

- a. Connect Cable 1 and one end of Cable 2 to the corresponding interfaces of the main unit, then insert the main unit into the upper grid.
- b. Connect the other end of Cable 2 to the input interface of Sub Module 1. Connect one end of Sub Module 1 and insert it into the middle grid.
- c. Connect the other end of Cable 3 to the input interface of Sub Module 2. Insert it into the bottom grid.
5. Fix the cover and the main unit with 2 socket head cap screws by using a hexagon wrench.

★ Surface Mounting with Protective Shield

1. Paste the installation sticker 1 onto the wall. Make sure the sticker is placed horizontally via measuring with the gradienter. Drill 4 holes according to the screw holes on the sticker.
Note: The suggested size of hole is 6(diameter) × 25(depth) mm. The suggested length of the cables left outside is 270 mm.
2. Remove the sticker and insert the expansion sleeves into the screw holes. Fix the mounting frame onto the wall with 4 expansion bolts.
3. Thread the module-connecting line across the thread holes of the frame. Pass the main unit connecting line across the thread hole to the top grid and connect the cables.
 - a. Connect the lines and module-connecting line 1 to the corresponding interfaces of the main unit, then place the main unit into the upper grid.
 - b. Connect the other end of the module-connecting line 1 to the input interface of the sub modules via module-connecting line 2.
 - c. Organize the cables with cable tie in the package.
4. Insert the modules into the frame after wiring. The main unit must be placed in the top grid.
5. Use the hexagon wrench in the package to fix the cover onto the frame.

4 Installation Positions

Recommended Installation Height (The distance between the camera and the ground): 1.4 m to 1.6 m
The FOV of the camera is : Horizontal: 146°, Vertical: 82°.
The highest visual height and lowest visual height of the camera is shown as picture

1

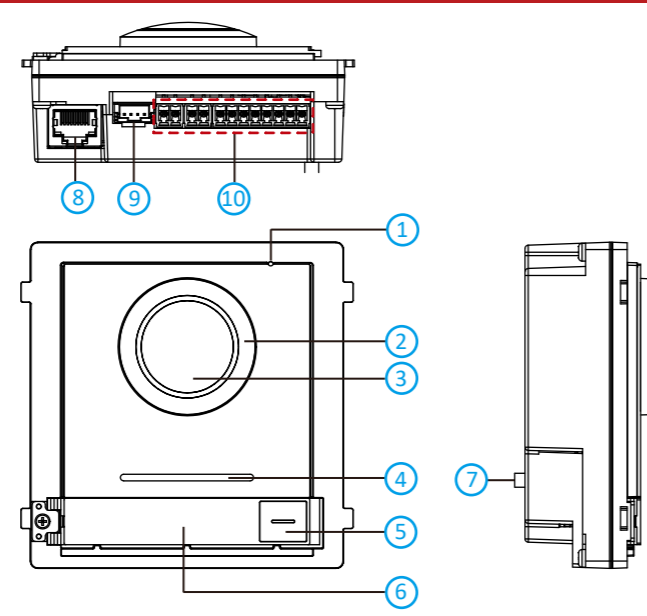

2

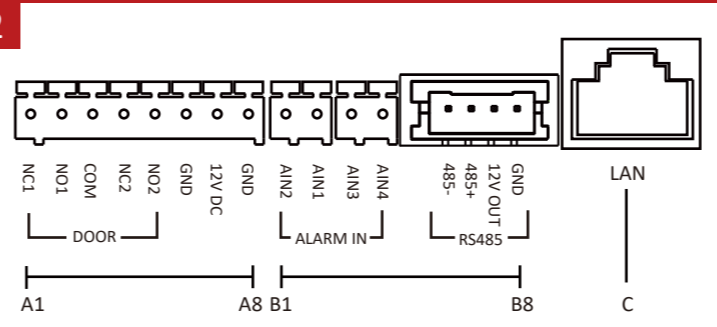

Scan the QR code to view User Manual for details.

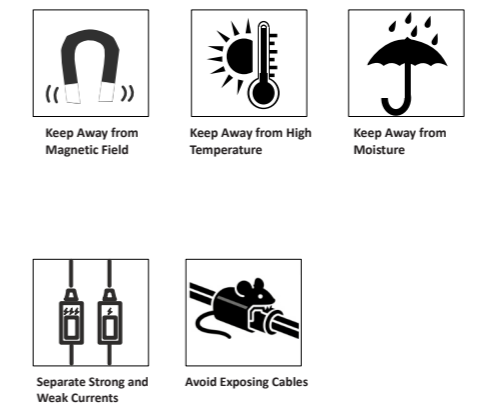

4

Recommended Installation Height (The distance between the camera and the ground): 1.4 m to 1.6 m

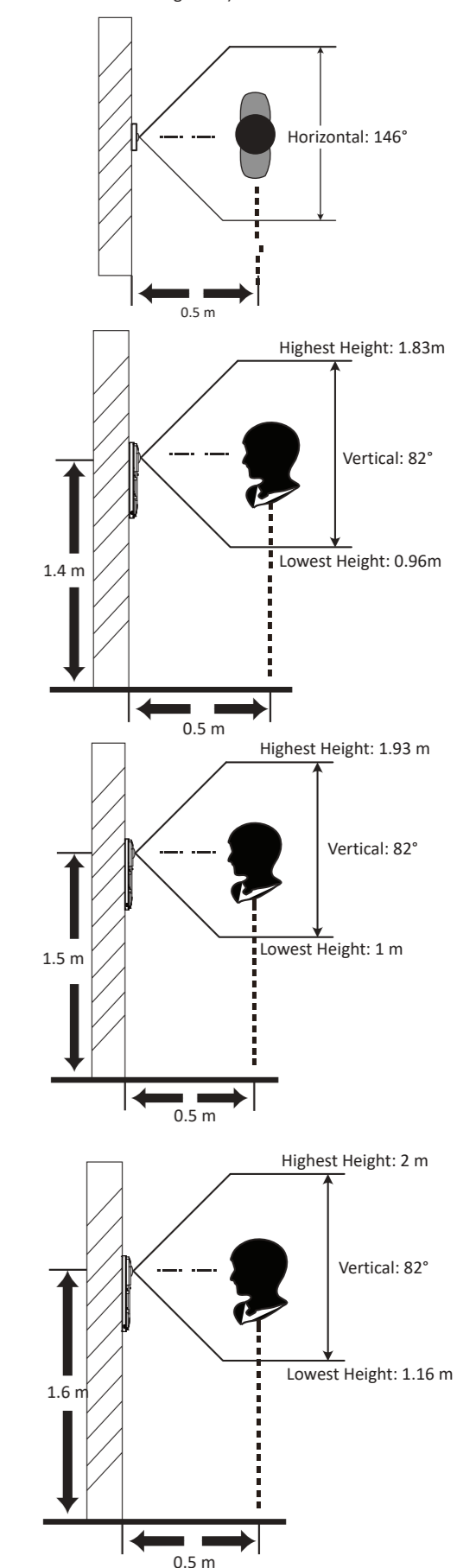

3

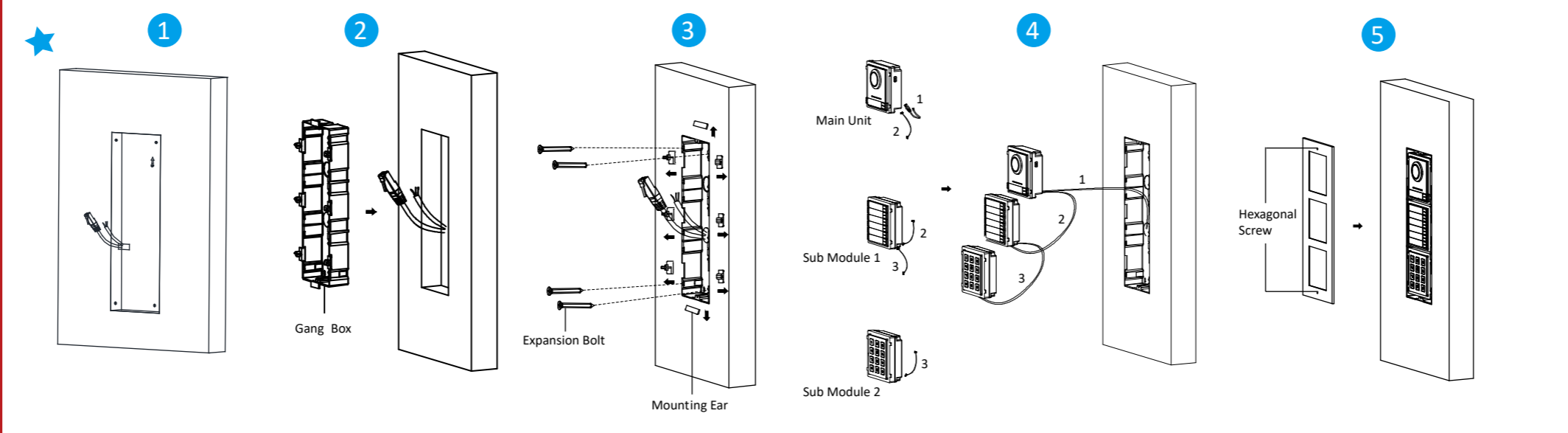

3

